

# HEAT PUMP AIR-WATER

**Model: LWR-8kW**

## Operational manual

- Please read this manual carefully, otherwise the mechanism can become irreversibly damaged.
- REVEL is not responsible for damages incurred by operation or assembly of the heat pump that were at variance with this operational manual.
- Working temperature of the surrounding air should range between  $-15^{\circ}\text{C}$  to  $+35^{\circ}\text{C}$
- Temperature of water entering the heat pump cannot exceed  $60^{\circ}\text{C}$  under any circumstances, even when the heat pump is not in operation!!

It is recommended that a bivalent source should be used with the heat pump during very cold days, the best option is an electric socket, 6 or 9 kW, provided by the company (see graph).

## Illustration of heat pump function

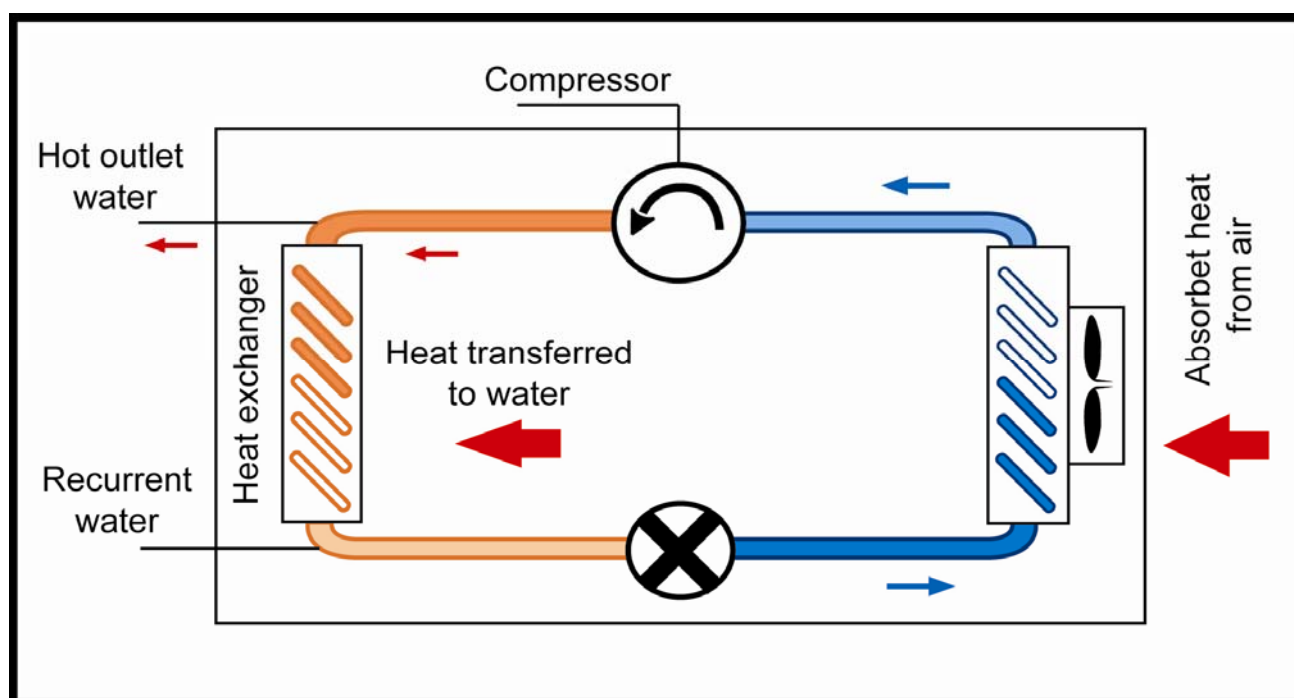

## Important information

1. Antifreeze can/does not have to be used as a heating medium depending on the heating system. In case of water, a constant operation of circulating pump must be supplied, which will provide flow of water through LWR-8kW.
2. During operation under low temperatures, the unit performs an automatic defrosting that is accompanied by drainage of defrosted condensed fluid of air moisture.
3. The mechanism is fixed with heating cable, which is in operation for the duration of defrosting. It is suitable to place the outlet the heating cable into sewerage, drainage, etc.
4. If the outlet of condensed fluid is defective and the HP freezes, short external intervention is needed in order to defrost the system, with the use of a tent or bowl fire, for example.
5. It is necessary to protect the heat pump at the point of water inlet by periodical cleaning of the filter.

## Technical and output parameters of HP

	Unit	LWR-8kW
Nominal capacity	kW	8
Power supply	V	230
Input power	kW	2,1
Operating current	A	9,5
Compressor	Type	Highly-rotary
Coolant medium	R407c	
Coolant amount	Kg	1,6
Water input and output	G	1" in
Ventilator noise	dB	49/3m
Ventilator power input	W	50
Min. working temperature	°C	-15
Max. output temperature	°C	56
Proportions (length/width/height)	Mm	1130/430/710
Weight	Kg	69
Output at 0/+55°C	kW	6,1
Output at -5/+55°C	kW	5,0
Output at -10/+55°C	kW	4,1
Output at 0/+35°C	kW	7,6
Output at -5/+35°C	kW	6,5
Output at -10/+35°C	kW	5,6

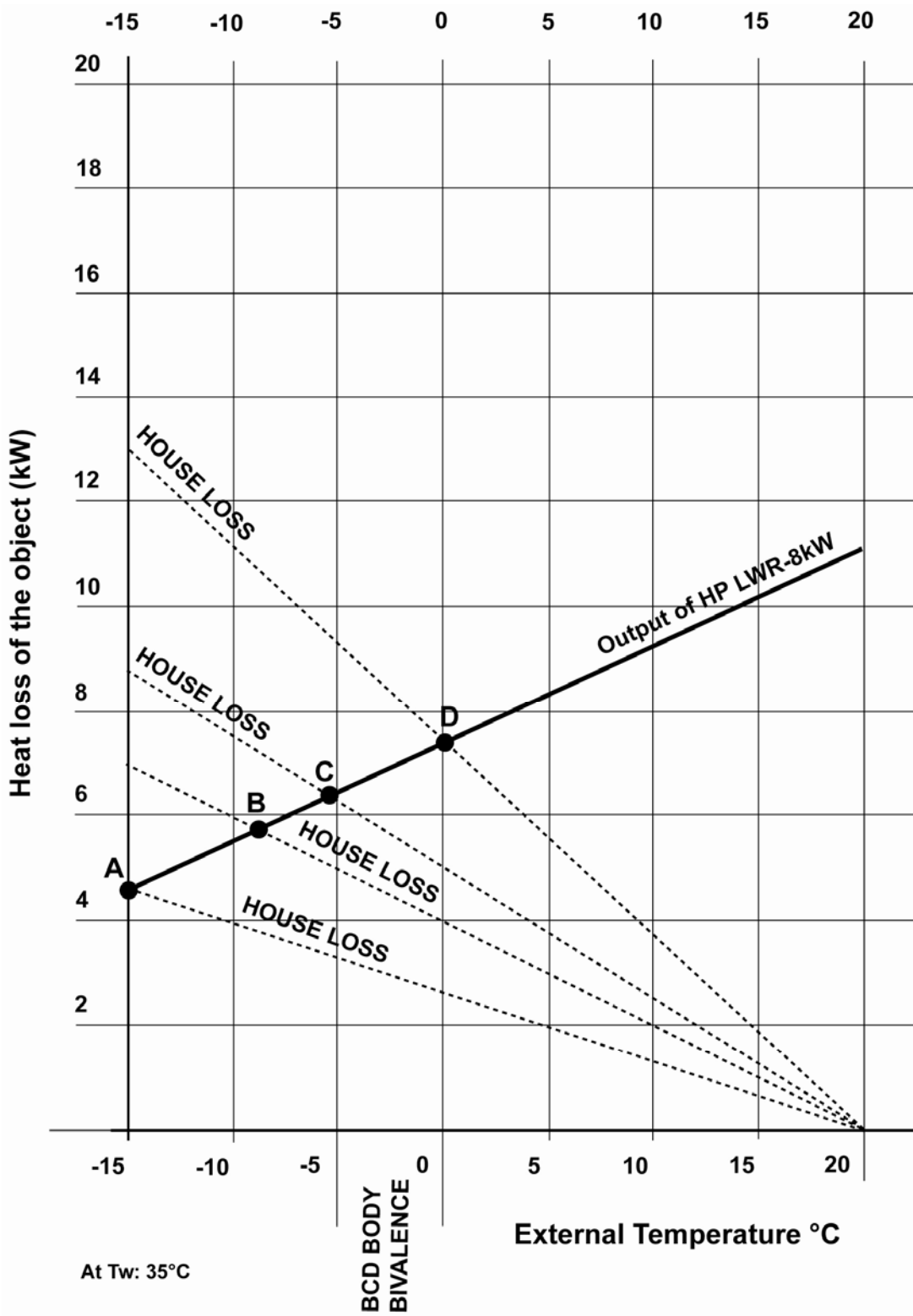

**GRAPH FOR HP LWR-8kW**

## Heat pump regulation

One of the components of the HP type LWR-8kW is digital regulator with an LCD panel, which is placed inside the building. Putting the system into operation without the regulator is impossible, and a replacement regulator is supplied only in exchange for damaged one (precaution against theft of the heat pump).

Functions and parameters of the HP are set on the regulator. In addition, the regulator provides error messages – see table. The HP can be controlled by automatic mode or manually. The system is released from production set to default. Only a selection of possible settings is available to the casual user. The system can be controlled in two ways.

A/ standard and recommended control is according to the temperature of the entering water into LWR. The requested upper limit on the regulator (module 1) and the critical bottom limit for activation of the electric boiler (module 0). Hysteresis for repeated activation of the system for acquirement of the upper limit cannot be set, and it is 5°C.

B/ second option is a control of the system through a room thermostat, which suggest some hysteresis (see connection diagram). However, thermostat is not a subject of supply and the particular electric terminal is interconnected. The system is protected from cycling by 3 min. interval; however, the requested value of recurrent water (module 1) can still be increased through this type of regulation.

The system does not display output temperature, which can be 3 to 10°C higher that input temperature according to the flow rate. It is recommended that the system is operated with the flow rate of approx. 2000 l/h, when it has the highest efficiency. This corresponds to the delta of approx. 3°C.

## Regulator control

- 1 – Time is set when the regulator is off with pressing down the button „SET“, when the clock sign appears. The time is set with the help of arrows. This process is repeated for the setting of minutes and the whole process is confirmed by pressing down the button SET“
- 2 – By pressing down the button ON, LCD display lights up. The screen displays all symbols of the control device, which signal that the regulator is connecting to the unit and communicating with it. If the connection does not occur within ten seconds, the communication with the unit was unsuccessful. It is necessary to check, whether the regulator is connected correctly. In case of successful communication, the stand-by mode is started, and it is switched to the operating mode, which displays the time, current temperature of the recurrent water and the program in progress.
- 3 – The automatic regime or manual control can be set by pressing down the button „M“.
- 4 – Holding down the arrows ”▲▼“ allows changing and browsing through the settings of the parameters.
- 5 – The button SET confirms the storage, selection, opening, and cancelation of the parameter.
- 6 – Press the up and down arrows until the reading “0-15” appears. If „0“ is the number of the module of the programming unit, the code „15“ represents the above range of the pre-set temperature after the activation the electric reserve source of heat.

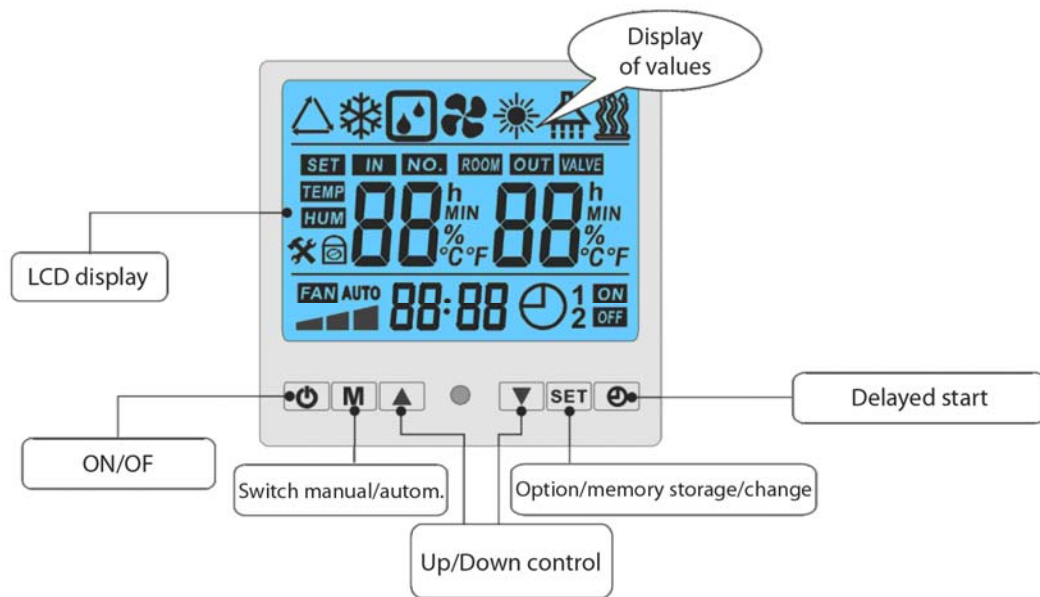

## Examples of displays on the controlling device – 21°C temperature of input water

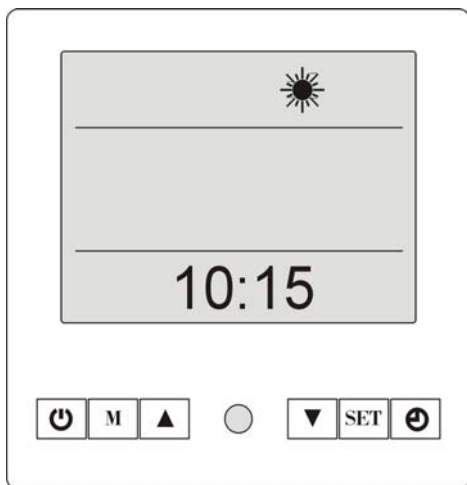

System in stand-by mode

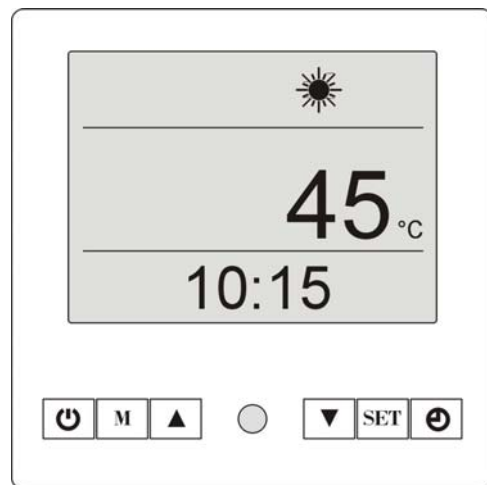

System in operation mode

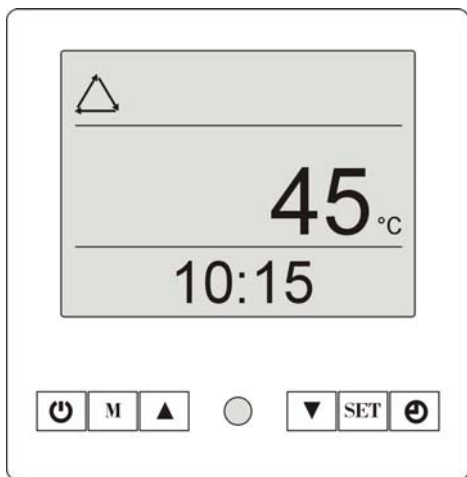

The system in automatic mode

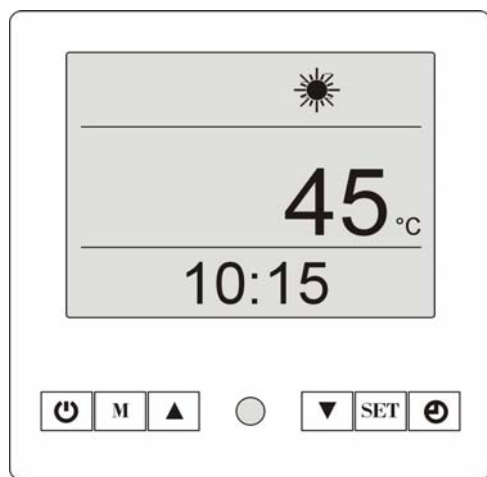

Sun is flashing – the system is defrosting

Parameter	Parameter meaning	Range	Production setting
0	Temperature setting for el. boiler attachment	0-30°C	25
1	Temperature setting of input water (reverse)	10-55°C	35
2	Defrosting cycle	30to90Min	57
3	Initial temperature for defrosting	0--30°C	-7
4	Terminal temperature for defrosting	30°C	30
5	Time for termination of defrosting	1to12Min	5
6	Number of systems	1-2	1
7	With/without protection of power supply shutoff	0-1	1
8	Expansion valve manually/automatic	0-1	1
9	With/without circulating pump	0-1	1
A	With/without protection against freezing	0-1	0
B	Setting of overheating degree	-F-F	7
C			
d		°C	
E		°C	
F	Temperature of the system cooling piping	°C	
10	Temperature of the cooling piping of the recurrent gas	°C	
11	Outside temperature	°C	
12	Temperature of the tank/reverse	°C	
13	Current position of the expansion valve	0-50	

### **Description of the parameters in the regulator and table:**

- Module “0“ performs activation of the reserve heating source by a control program upon acquirement of certain temperature
- Module “1“ performs setting of water temperature in storage tank or reverse
- Module “2“ performs setting of duration between individual defrosting cycles of the heating pump in order to remove air-moisture frost on the unit. During increased frost deposition in the outside unit, these cycles are shortened.
- Module “3“ defrosting activation of the outside unit at set value. Only in automatic mode.
- Module “4“ set temperature for activation of the outside unit during the defrosting cycle (upon acquirement of the correct temperature, the heating function of the unit is initiated)
- Module “5“ time setting for maximum time of the defrosting cycle

- Module “6” number of interconnected systems (for example, two HP in parallel connection into the storage tank)
- Module “7” automatic activation of the system during the electric supply failure (delayed start)
- Module “8” heat pump output control in dependence on outside temperature (setting of the coolant injecting valve)
- Module “9” for control of the circulating pump (controlled in compliance with module “0”)
- Module “A” not activated (intended for other climatic conditions)
- Module “B” recommended temperature setting of the coolant fluid at 7°C
- Module “C” setting of the expansion valve in dependence on the output of the HP (outside temperature) via module 8 is controlled automatically
- Module “D,E,F,10,11,12,13” are operating data, according to which the aforementioned settings are adjusted depending on the operational needs.

### Table of errors and protection

Protection / error	Display on the control device
Stand-by mode	
Normal mode	
Sensor error for reading of input water temperature	PP1
Sensor error for reading of output water temperature	PP2
Sensor error for reading of temperature spiral	PP3
Sensor error for reading of water from condenser	PP4
Sensor error for reading of outside temperature	PP5
Sensor error for reading of temperature in water tank / reverse	PP6
Protection against freezing	PP7
High-pressure system protection	EE1
Low-pressure system protection	EE2
Error of water flow switching device	EE3
Insufficient power supply	EE4
Water pressure error	EE5
Error in communication with long distance electric control	EE8
Defrosting	Defrosting flashes

### Illustration of error messages on the control device

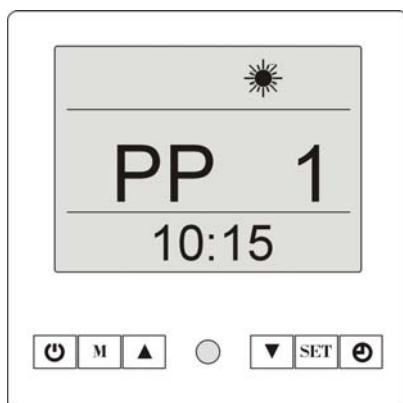

Example of sensor error

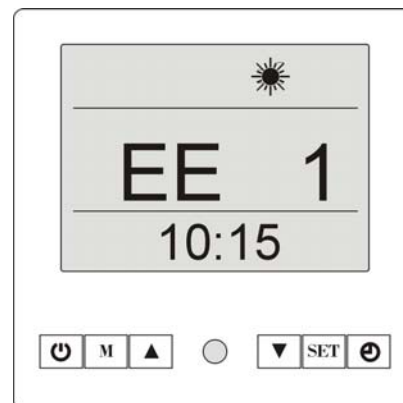

Example of protection via high-pressure sensor

# Connection Diagram of LWR-8kW

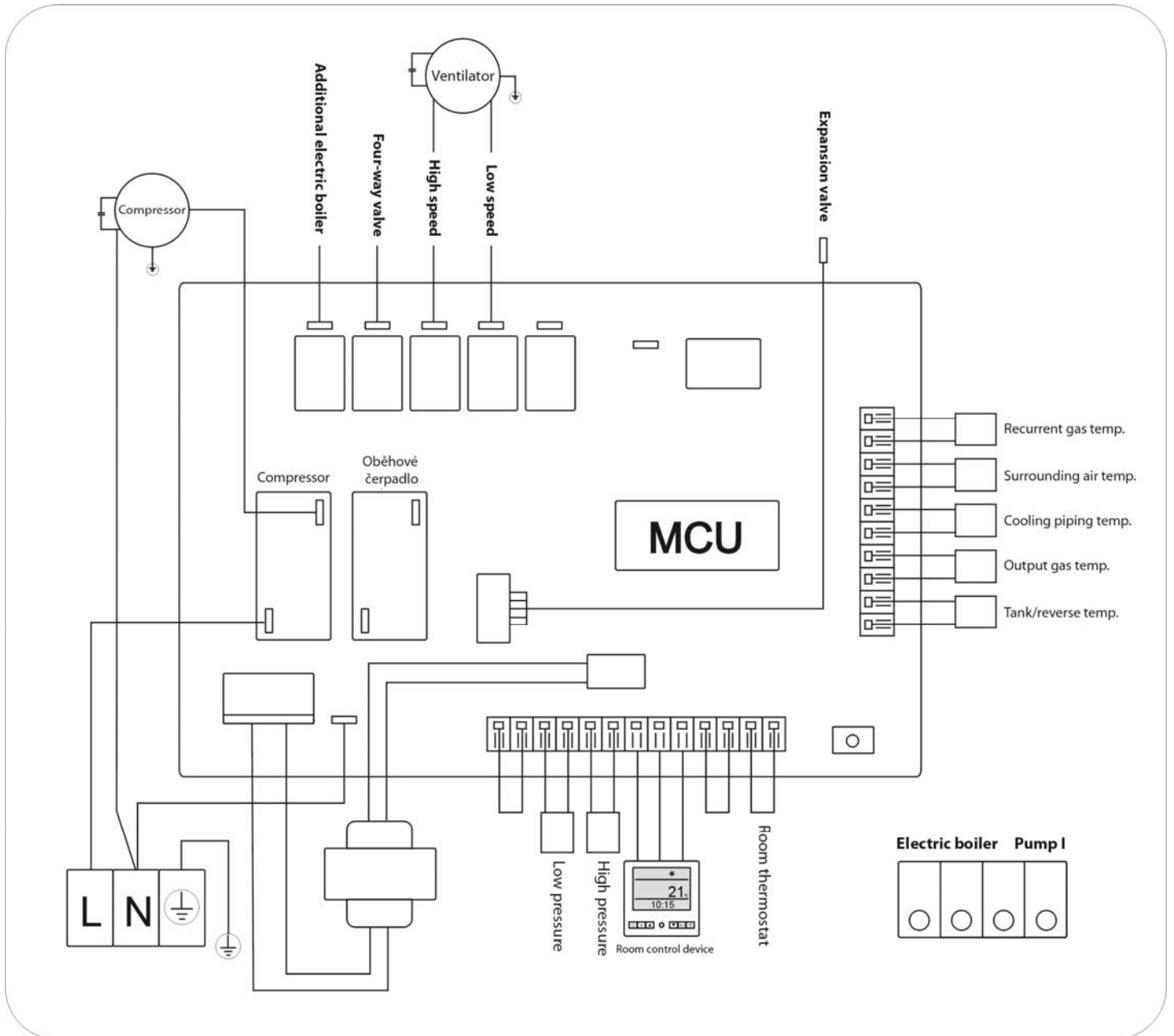

## Installation instructions

- The system can be installed only by an authorized person, restricted electric systems
- The unit is intended for **230V/50Hz** power supply
- Recommended protection for model **LWR-8kW** is **16A/C**

The system should be installed outside in a position that ensures smooth air circulation, preferably vertically to the wall of the building. It is suitable to install the system near a drainage canal 20-40 cm above the terrain. The unit should be mounted by screws over rubber anti-vibration silen blocks to the permanent construction according to the character of the building; however, it should not be connected to the structure or its foundations. Select the area of placement in a way that the noise does not travel into premises designated for resting in one's own or neighboring property.

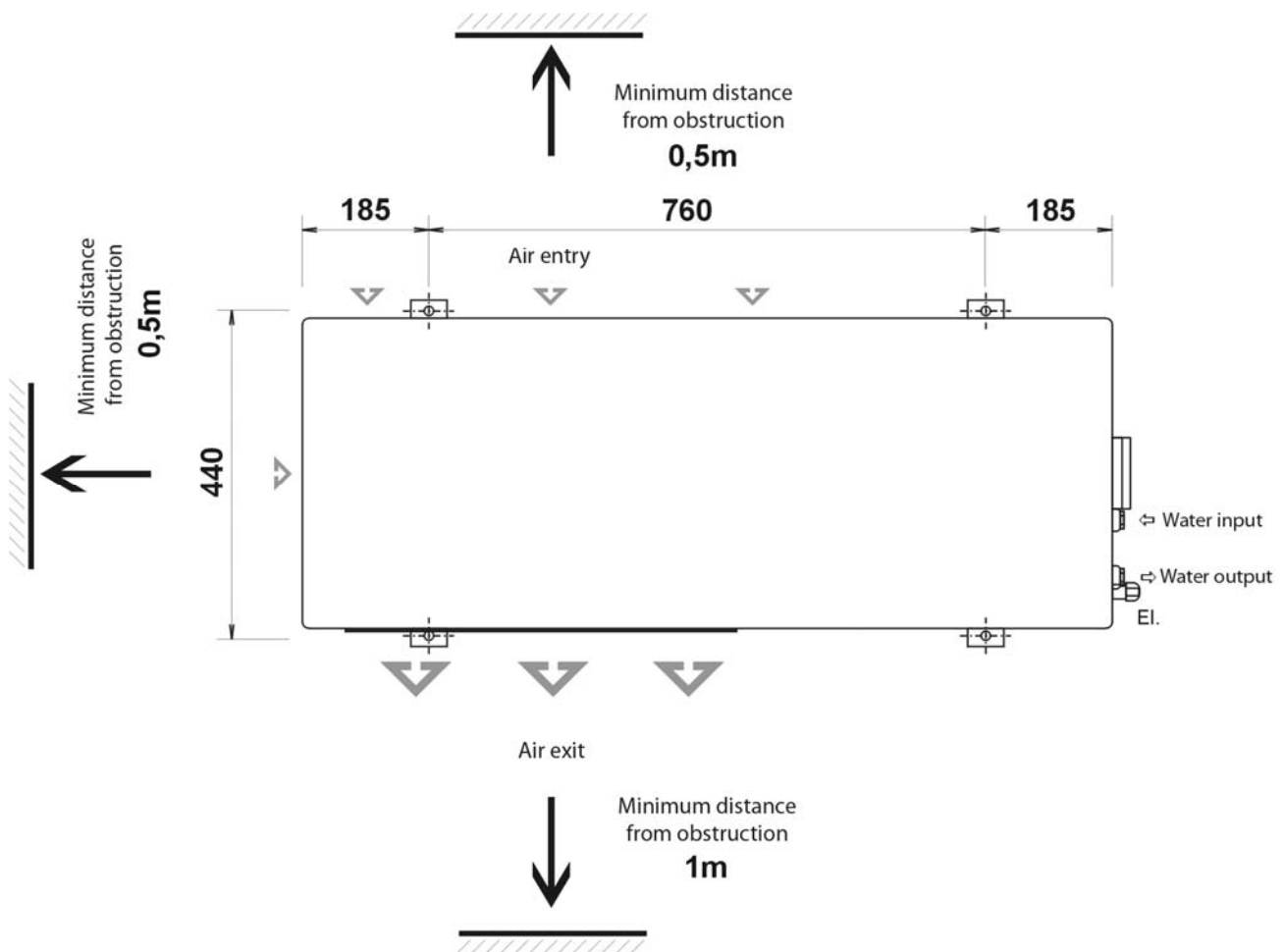

## **Activation of heat pump**

- Check, whether the HP is properly shielded and no foreign object are present on its surface.
- Check, whether the unit is properly filled and deaerated.
- Check, whether water flow through the HP is supplied.
- Check the system's connection to the electric supply and grounding.
- Turn on the heating pump, the system will automatically start operating in 3 minutes.
- Determine, whether the pump rotates smoothly without making any unusual noises, and the unit does not shut down in short intervals (under 15 minutes).
- Check, whether the HP supplies thermal energy and observe increase in temperature of the input and output water.
- Perform periodical check-ups of the unit during period of low outside temperatures, and in case of freezing, reset the time parameters for defrosting (also depends on the presence of water sheet in the surrounding area of the system)

## **Maintenance**

Heat pump LWR-8kW is fully automatic.

- Input water filter must be periodically cleaned.
- Periodically clean the air part of the heating pump from solid impurities and dust.
- If there is anything wrong with the unit, and the customer is not able to solve the problem, contact the supplier or our company for removal of the problem.
- The system must be operated with water that meets the requirements of heating water (max. 7 degrees of hardness and range between 7.8-8.5 pH)